

Haldex

Midland Services

Tractor Troubleshooting Guide

HALDEX MIDLAND CORPORATION
10707 N.W. Airworld Drive
Kansas City, Missouri 64153-1215
Phone: (816) 891-2470 • Fax: (816) 880-9766

HALDEX MIDLAND CORPORATION
Customer Service Department
10930 North Pomona Avenue
Kansas City, Missouri 64153-1297
Phone: (800) 643-2374 • Fax: (800) 533-1941

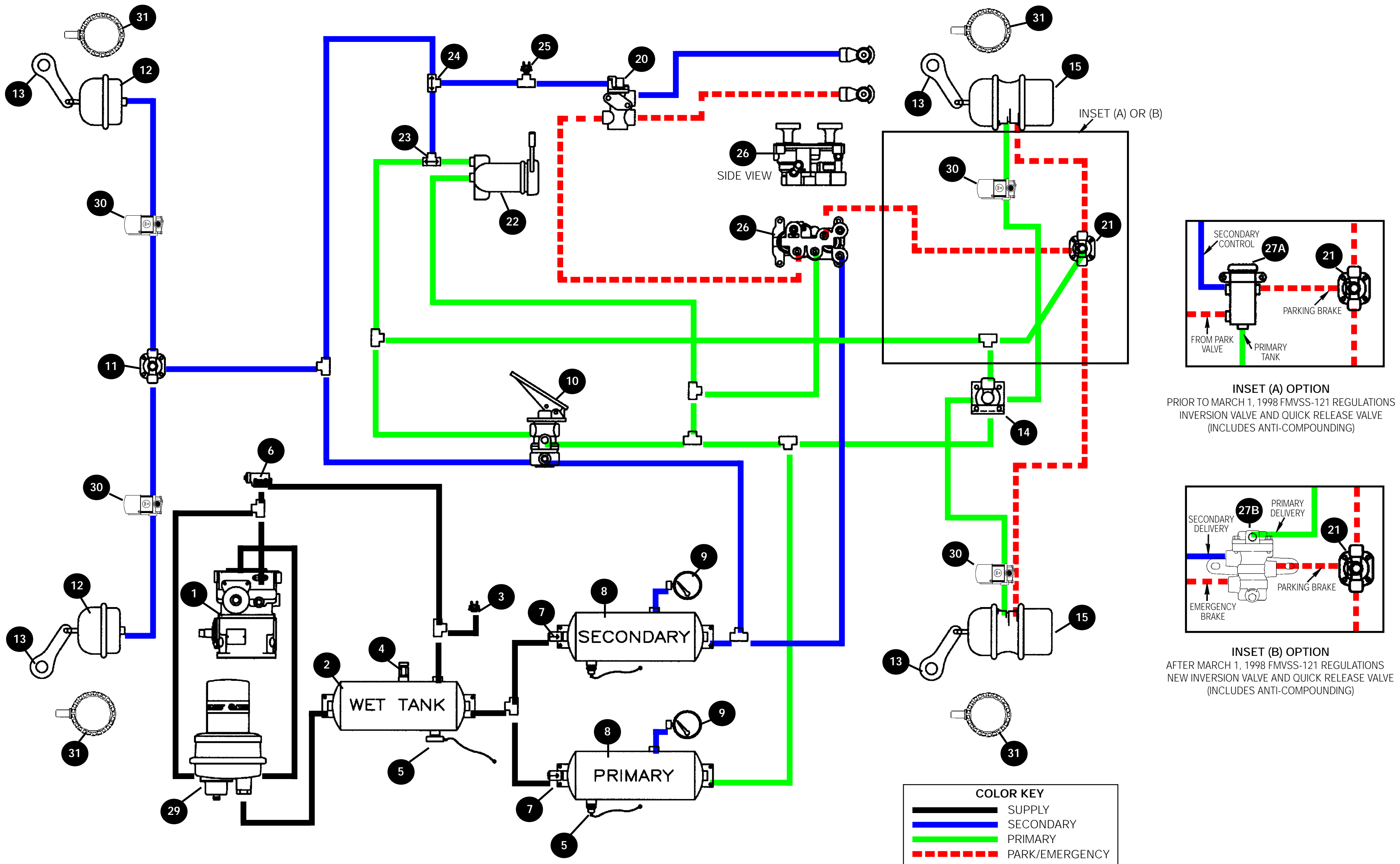

COMPLAINT/REMEDY

1 COMPRESSOR

- PUMPS BEYOND "CUT-OUT"
 - ◆ Check gauge.
 - ◆ Check governor.
 - ◆ Be certain it pressurizes unloader port when above "cut-out."
 - ◆ Check unloader/plungers. Lube, kit or change head.
- WON'T PUMP AIR
 - ◆ Check gauge.
 - ◆ Check compressor drive.
 - ◆ Check inlet valves and plungers. If stuck, leak will be evident at intake when unloaded. Install unloader kit, head kit or head assembly.
- SLOW PRESSURE BUILD-UP
 - ◆ Check gauge.
 - ◆ Check compressor drive.
 - ◆ Check intake for restriction.
 - ◆ Check discharge line for restriction.
 - ◆ Check unloader function. Lube or kit.
 - ◆ Check inlet and exhaust valves. Leak will be evident at intake when unloaded. Kit or exchange head.
- PUMPS EXCESSIVE OIL
 - ◆ Check oil return for restriction, kink or loop.
 - ◆ Check for gasket sealant obstructing drain.
 - ◆ Check for undersize return line (1/2" minimum).
 - ◆ Check for fitting restricting drain.
 - ◆ Check for intake vacuum (20" water maximum).
 - ◆ Check for excessive engine crankcase pressure (poor engine ventilation).
 - ◆ Check compressor ring wear. Exchange for service unit.

2 WET TANK

- EXCESS OIL ACCUMULATION
 - ◆ See PUMPS EXCESSIVE OIL (above).
- EXCESS WATER ACCUMULATION
 - ◆ Drain daily. Install automatic drain on wet tank.
- DAMAGED WET TANK
 - ◆ Replace.

3 LOW PRESSURE INDICATOR SWITCH

- BUZZER OR LIGHT INOPERABLE
 - ◆ Check ground and wiring on switch and buzzer/light.
 - ◆ Replace switch or buzzer light.
- WON'T OPERATE AT PRESSURES BELOW 60 P.S.I.
 - ◆ Check dash gauge for accuracy.
 - ◆ Replace switch or buzzer light.

4 SAFETY VALVE

- "POPS" OFF EXCESSIVELY
 - ◆ Check system pressure.
 - ◆ Valve operating properly in venting at 140/150 P.S.I.
 - ◆ Check unloader/governor.
- "POPS" OFF AT LESS THAN 140 P.S.I.
 - ◆ Replace.
- LEAKS
 - ◆ Replace.
- WON'T FUNCTION
 - ◆ Periodic Test: remove and test above 150 P.S.I. with shop air.
 - ◆ Replace if non-functional.

5 DRAIN VALVES - MANUAL

- LEAKS
 - ◆ Replace.

5 DRAIN VALVES - AUTOMATIC

- WON'T DRAIN
 - ◆ Repair or replace.
- WON'T DRAIN IN COLD WEATHER
 - ◆ Replace with heated unit.
- LEAKS - MALFUNCTIONS
 - ◆ Repair or replace.
 - ◆ Periodic Test: with system pressure stabilized (compressor unloaded) no leak evident at discharge port - make several foot brake applications to reduce wet tank pressure. Moisture should drain from discharge port.

6 GOVERNOR

- FLUTTERS
 - ◆ Check gauge.
 - ◆ Check unloader line size (5/16" x 5' maximum).
 - ◆ Check air actuated accessory. Is the air volume requirement greater than governor capacity?
 - ◆ Check for plugged governor reservoir line.
 - ◆ Repair, adjust or replace governor.
- WON'T PASS AIR TO UNLOADER TO "CUT-OUT" COMPRESSOR
 - ◆ Check governor reservoir line..
 - ◆ Repair or replace.

COMPLAINT/REMEDY

7 SINGLE CHECK VALVE

- ALLOW BLEED BACK TO SUPPLY RESERVOIR
 - ◆ Periodic Test: bleed supply reservoir and observe gauges. Check valves should maintain rear and front reservoir pressure.
 - ◆ Replace if test results are negative.

8 PRIMARY & SECONDARY RESERVOIR

- EXCESS OIL/WATER
 - ◆ Drain as required.
 - ◆ Check automatic drain valve on wet tank for proper operation (See #5).

9 AIR GAUGE

- INCORRECT READING
 - ◆ Calibrate or replace.

10 DUAL SYSTEM FOOT BRAKE VALVE

- LEAKS AT EXHAUST WITH ALL BRAKES RELEASED
 - ◆ Check anti-compound double check valve #21.
 - ◆ Check #20 and #27a & 27b for back flow into service control line.
 - ◆ Check trailer air system for back flow into tractor's service control line.
- CAUTION: CHOCK WHEELS - Repair and replace items as necessary.
- LEAKS AT EXHAUST WITH HAND VALVE APPLIED
 - ◆ Check double check valve #23 or #24. Repair or replace.
- LEAKS AT EXHAUST WITH FOOT BRAKE APPLIED
 - ◆ Foot valve defective. Repair or replace.
- LEAKS AT EXHAUST WITH ALL PARK BRAKES SET IN PARK POSITION AND FOOT BRAKE RELEASED
 - ◆ Foot valve defective. Repair or replace.

11 QUICK RELEASE VALVE

- LEAKS AT EXHAUST PORT WITH ALL BRAKES RELEASED
 - ◆ Check and replace #27b if back flow occurs into service delivery line.
- LEAKS WHEN SERVICE BRAKES ARE APPLIED
 - ◆ Repair or replace.

12 SERVICE BRAKE CHAMBER

- LEAKS
 - ◆ Replace diaphragm.
 - ◆ Cage park brake.
 - ◆ Reset clamps.
 - ◆ Adjust brakes.
- WITH SERVICE BRAKES APPLIED STROKE IS AT OR BEYOND MAXIMUM LIMIT OF:
 - ◆ Type 9 1 3/8"
 - ◆ Type 12 1 3/8"
 - ◆ Type 16 1 3/4"
 - ◆ Type 20 1 3/4"
 - ◆ Type 24 1 3/4"
 - ◆ Type 30 2"
- SLUGGISH APPLICATION OR RELEASE
 - ◆ Check basic brake.
 - ◆ Check for air line restriction/leak.
 - ◆ Align linkage.
 - ◆ Check chamber return spring.
 - ◆ Adjust brakes. Angle should approach 90° on application.
 - ◆ Check for improper chamber or obstruction.

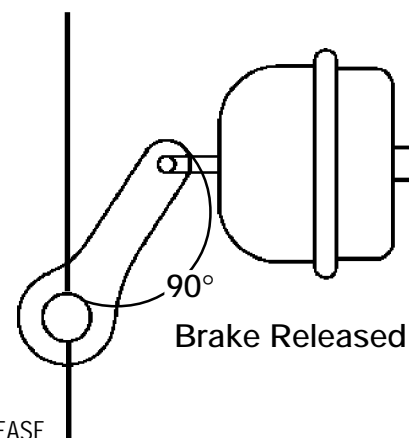

13 SLACK ADJUSTER

- SLEEVE WILL NOT DEPRESS
 - ◆ Clean and lubricate or replace with unit dimensionally same.
- ADJUSTING SHAFT WILL NOT TURN
 - ◆ Replace with unit dimensionally same.
- CRACKED HOUSING
 - ◆ Check spring brake anti-compound system.
 - ◆ Check air chamber size. Replace if larger than original size.
 - ◆ Check direction of travel for proper position of hex nut (Shown Under #12).
 - ◆ Hex nut must face away from chamber for uni-directional slack adjuster.
- WORN CLEVIS PIN BUSHING
 - ◆ Replace bushing.

14 RELAY VALVE

- LEAKS AT EXHAUST PORT WITH ALL BRAKES RELEASED
 - ◆ Check seal in spring brake for back-flow of spring "hold-off" pressure through service port to open exhaust on valve. Replace #15 Spring Parking Brake.
 - ◆ Check and replace #27b if back flow occurs into service delivery line.
 - ◆ Check reservoir port for evidence of contamination, check supply lines for rusty fittings or carbon deposits. Repair or replace.
- LEAKS AT EXHAUST PORT WITH SERVICE BRAKES APPLIED
 - ◆ Exhaust valve not seating properly. Repair or replace.

COMPLAINT/REMEDY

15 SPRING PARKING BRAKE (SERVICE ONLY SERVICE CHAMBER SIDE OF SPRING BRAKE)

- PARK BRAKE DRAGS OR WON'T RELEASE
 - ◆ Check For: Improper adjustment, restriction or broken line. Diaphragm failure. System pressure too low. Improper manual release. Broken return spring (spring side). Quick release of relay malfunction. Broken power spring.
 - ◆ Replace entire unit or piggy-back emergency section.
- SLUGGISH PARK APPLICATION
 - ◆ Check For: Diaphragm failure. Improper manual release. Broken power spring.
- LEAKS WHEN PRESSURIZED FOR PARK BRAKE RELEASE
 - ◆ Check For: Ruptured spring side diaphragm. Push rod seal leakage (may be evident at #14 relay valve).
- SERVICE CHAMBER MALFUNCTION
 - ◆ See #12 service brake chamber.

16 DOUBLE CHECK VALVE UNITES FRONT BRAKE AND REAR BRAKE RESERVOIRS TO FEED PARK CONTROL (INSET B OPTION WITH TWO VALVE DASH PANEL)

- REAR TANK BLEED-DOWN ALSO BLEEDS FRONT TANK OR VICE VERSA
 - ◆ Periodic Test: Pressure should remain in one tank after the other is drained. Replace if not functioning properly.

20 TWO-LINE TRACTOR PROTECTION VALVE (NON-AUTOMATIC TYPE)

- WILL NOT RESPOND TO TRAILER CHARGE VALVE
 - ◆ Defective valve. Repair or replace.
- SUPPLY LINE TO TRAILER WITH SLOW BLEED-DOWN DOES NOT SHUT OFF TRACTOR AIR AND VENT BETWEEN 45 P.S.I. AND 20 P.S.I.
 - ◆ Check trailer charge valve #26, as it should "pop" to let T.P. valve vent trailer supply. Repair or replace.
- LEAKS AT EXHAUST PORT OR TRACTOR SERVICE (BACK THROUGH HAND OR FOOT VALVE) OR TRAILER SUPPLY
 - ◆ Defective valve. Repair or replace.

21 QUICK RELEASE AND DOUBLE CHECK VALVE COMBINATION

- FOOT VALVE EXHAUST LEAK PARK BRAKES RELEASED YELLOW DASH CONTROL VALVE EXHAUST LEAK IN PARK POSITION AND SERVICE BRAKES APPLIED
 - ◆ Check anti-compound double check valve portion for feedback to foot or dash control valve. Repair or replace.

22 HAND CONTROL VALVE-TRAILER SERVICE BRAKES

- LEAKS AT EXHAUST PORT WHEN RELEASED AND FOOT VALVE IS APPLIED
 - ◆ Check #23. Replace if necessary.
- LEAKS AT EXHAUST PORT WHEN RELEASED AND TRAILER PARKING BRAKES ALSO RELEASED
 - ◆ Check #20 for internal backflow into service control line, or trailer air system for backflow into tractor service control line.
- LEAKS AT EXHAUST PORT WHEN RELEASED OR APPLIED AND ALL PARKING BRAKES IN PARKED POSITION
 - ◆ Hand control valve is defective. Repair or replace.

23 DOUBLE CHECK VALVE SEPARATES TRAILER HAND VALVE PRESSURE FROM REAR FOOT BRAKE PRESSURE FOR DELIVERY TO TRAILER

- FOOT VALVE EXHAUST PORT LEAKS WHEN HAND VALVE IS APPLIED
 - ◆ Replace.
- HAND VALVE EXHAUST PORT LEAKS WHEN FOOT VALVE IS APPLIED
 - ◆ Replace.

24 DOUBLE CHECK VALVE SEPARATES FRONT AXLE FOOT BRAKE PRESSURE FROM REAR AXLE FOOT BRAKE PRESSURE AND/OR TRAILER HAND VALVE PRESSURE FOR DELIVERY TO TRAILER

- LEAKS THROUGH FOOT VALVE EXHAUST WITH HAND VALVE APPLIED
 - ◆ Replace #23 or #24.
 - ◆ Periodic Test: Alternately loosen each inlet line and apply pressure to other. If leak is detected - replace.

COMPLAINT/REMEDY

25 STOP LIGHT SWITCH

- LEAKS
 - ◆ Replace.
- FAILS TO SIGNAL A GOOD BULB THROUGH SOUND WIRING AT 3-6 P.S.I.
 - ◆ Replace.

26 MANIFOLD DASH VALVE WITH BUILT-IN TWO-WAY CHECK (RED OCTAGON) TRAILER CHARGE (YELLOW DIAMOND) TRACTOR PARK

- PARK BRAKE WON'T RELEASE
 - ◆ Check for full system pressure delivery through valve.
- PARK BRAKE WON'T APPLY
 - ◆ Repair or replace, if it will not release pressure.
- LEAKS AT EXHAUST PORT IN PARK POSITION SERVICE BRAKES APPLIED
 - ◆ Check #21 anti-compound double check valve.
- LEAKS AT EXHAUST PORT IN PARK POSITION SERVICE BRAKES RELEASED
 - ◆ Repair or replace.
- WON'T APPLY TRAILER IMMEDIATELY WHEN "PULLED"
 - ◆ Replace, if it won't exhaust. Repair or replace #20 if #26 is functioning properly.
- REAR TANK BLEED-DOWN ALSO BLEEDS FRONT TANK OR VICE VERSA
 - ◆ Periodic Test: Pressure should remain in one tank after the other is drained. Replace, if inoperative.

27a INVERSION RELAY VALVE WITH THE LOSS OF REAR SERVICE BRAKES, APPLICATION OF SPRING BRAKE BY USING THE EMERGENCY SECTION SHOULD BE AVAILABLE ALONG WITH FRONT SERVICE BRAKE BY APPLYING FOOT VALVE

- Periodically test by bleeding rear service tank and observing front brake and rear spring brake application upon depressing foot pedal. Repair or replace, if after checking piping is not functioning properly.
- LEAKS
 - ◆ Repair or replace.

28 BARRIER WHEEL OIL SEALS (NOT SHOWN IN SCHEMATIC)

- OIL LEAK
 - ◆ Check for proper glazing of the sealing lip.
 - ◆ Check serrations on O.D. and I.D. to see that sealing surfaces are dry. If wet, this could denote the leakage path.
 - ◆ Check area between positioning pads. If wet, suspect seal leak.
 - ◆ Check seal for possible damage incurred during installation.
 - ◆ Check hub bore and spindle surfaces for imperfections or irregularities.
 - ◆ Check to be sure that proper seal has been installed for the particular axle application.

29 AIR DRYER

- AIR LEAKING CONSTANTLY FROM PURGE VALVE
 - ◆ Purge valve seal damaged. Replace.
 - ◆ Purge valve frozen.
 - ◆ Inspect heater (see heater problems).
- HEATER INOPERATIVE
 - ◆ Blown Fuse. Check fuse and replace with 8-10 amp fuse
 - ◆ Broken wires or poor connections. Repair or replace wiring to heater.
- SLOW WET TANK BUILD-UP
 - ◆ Filter and/or desiccant plugged. Service air dryer.

30 ABS INLINE VALVES

- FOR COMPLETE TROUBLESHOOTING INFORMATION, REFER TO LITERATURE PIECES MODAL POWER TK-2 INSTALLATION & SERVICE MANUAL (L30022) AND/OR ABS DIAGNOSTIC TROUBLESHOOTING GUIDE (L20293)

31 ABS SENSORS & EXCITER RINGS

- FOR COMPLETE TROUBLESHOOTING INFORMATION, REFER TO LITERATURE PIECES MODAL POWER TK-2 INSTALLATION & SERVICE MANUAL (L30022) AND/OR ABS DIAGNOSTIC TROUBLESHOOTING GUIDE (L20293)